

ParameterEinstellung

Schlüsselaster CAN:

- > 3s links = AUS
- > 3s rechts = AUTOMATIK

Multiport:

- i/o1 = Eingang; low Aktiv/Schlesser, Schlüsselaster 1 links
- i/o2 = Eingang; low Aktiv/Schlesser, Schlüsselaster 1 rechts

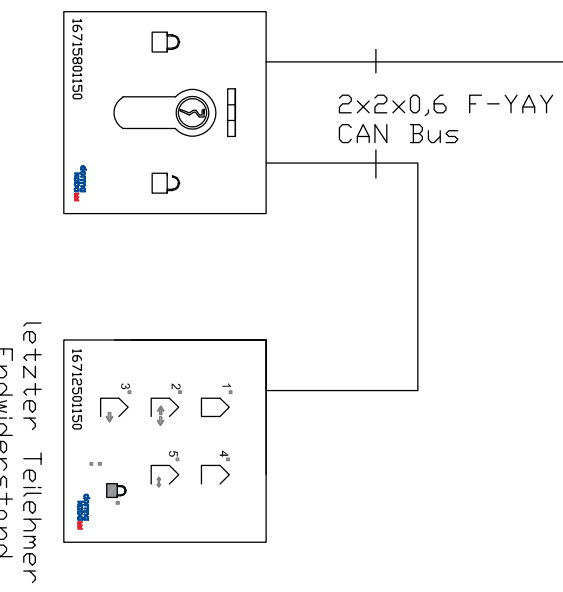
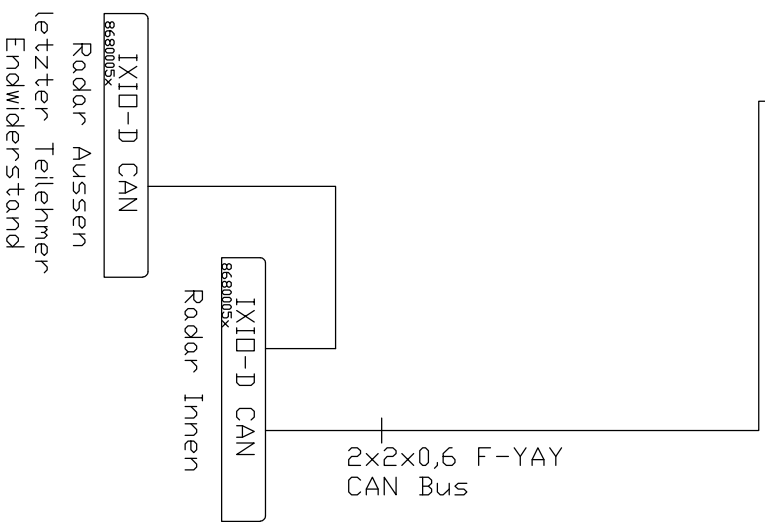
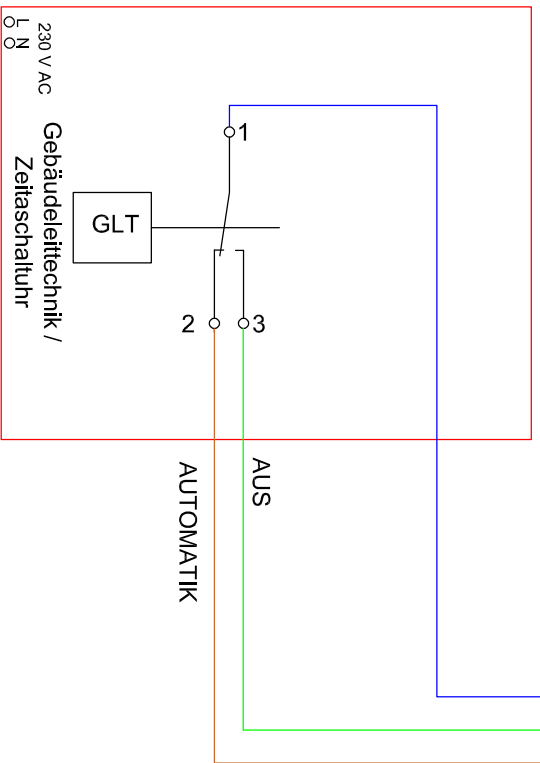
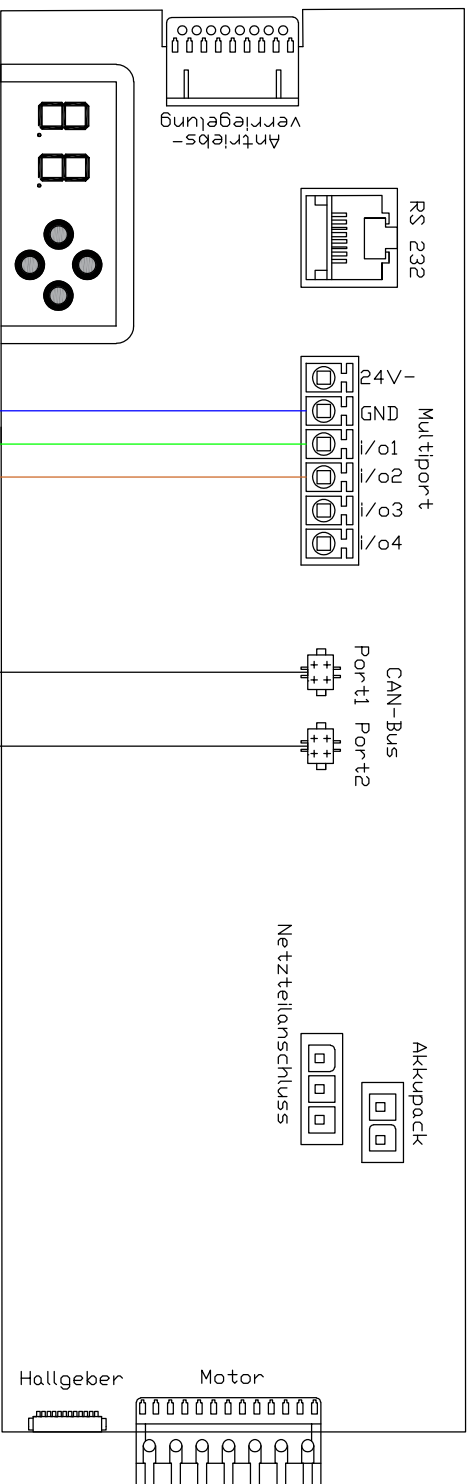

Objekt: Umschaltung durch Gebäudeleittechnik Anlage: Systemplan ES 250 / 400 Pro gespeichert unter: Tür-Nr.:	Format: A3 Bearb.: Bräunlinger	Maßstab: kein Datum: 12.07.2021	dormakaba Austria GmbH Gewerbestraße 1a A-5201-Seekirchen	
---	---	--	---	--